

SABRE VRN2a



Design

The Sabre VRN2a is a compact SF6 insulated Vacuum Ring Main Unit (RMU). The unit can be mounted to the smallest distribution transformer or be sited in a free standing format. Designed to be used both indoors and outdoors, the unit has a long service life and requires virtually zero maintenance.

Key features

- Compact Design
- 12kV and 15.5kV
- Indoor / Outdoor application
- Mimic Diagram
- Vacuum tee off circuit breakers
- Enhanced duty, in excess of IEC requirements
- Pre-wired for motor actuation
- Fault passage indicators
- Common switching chamber
- Full ratings with zero atmospheric pressure
- Isolation in clean SF6 gas

Options



Protection

All options provide transformer over current protection for phase to phase faults. Earth protection covering phase to earth faults is also available if required.



Cable Boxes

Internal arc test cable boxes are available with IEC and ENA specifications. Interlocked cable boxes are also provided as options.



Automation

The Sabre VRN2a can be pre-wired for automation. Single or double rotary actuators can be easily and rapidly fitted on site whilst the unit is in service – no access is required to the internal workings of the RMU.

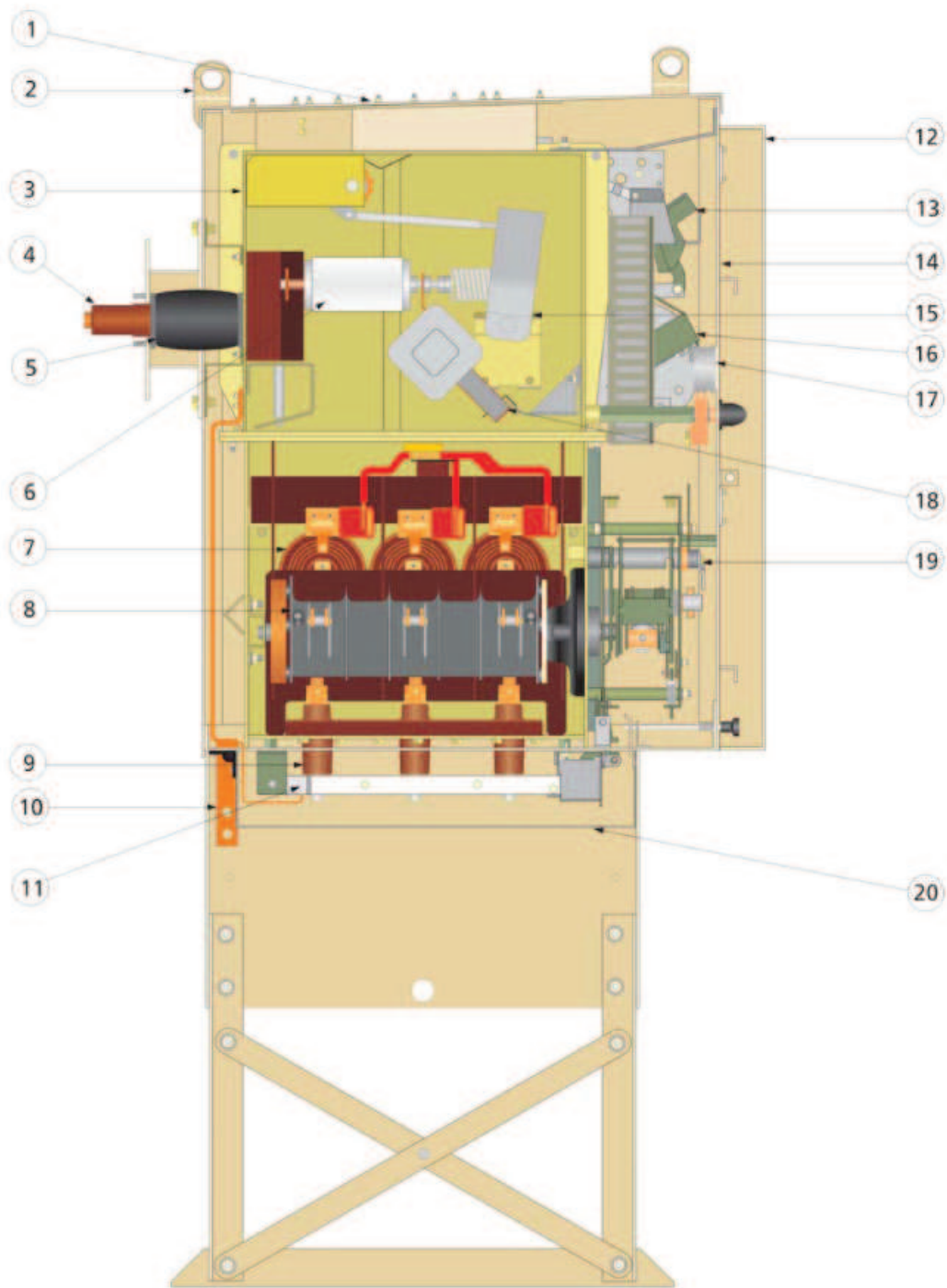

- | | |
|---------------------------------------|--|
| 1 Internal arc vent | 11 Removable and fully interlocked ring switch point earth |
| 2 Lifting lugs | 12 Access door |
| 3 Sealed tank | 13 Circuit breaker operation |
| 4 Tee-off cable terminations | 14 Fascia and mimic |
| 5 Protection CT's | 15 Vacuum interrupter drive beam |
| 6 Circuit breaker vacuum interrupters | 16 Two-position disconnector operation |
| 7 Ring switch cable termination | 17 Pressure gauge |
| 8 Three-position ring switch | 18 Two-position disconnector |
| 9 Ring cable test terminals | 19 Operating mechanism for ring/earth switch |
| 10 Primary earth point | 20 Test access cover |



DESIGN

The Sabre VRN2a is a non extensible RMU comprising of a Tee-off vacuum circuit breaker and two fault-make load break ring switches contained within a common SF6 gas insulated stainless steel enclosure. The unit is suitable for both indoor and outdoor applications and can be used either as a freestanding unit or for mounting to a transformer, complying with ENATS 35-1.

Stainless Steel Gas Enclosure

The gas enclosure is manufactured from stainless steel and fabricated utilising automatic 'robot welding' techniques to produce consistent leak-free equipment.

Housing

The housing of the Sabre VRN2a is fully treated; using zinc coated steel and electrostatically applied oven cured paint, to resist weather and pollution attacks. All units are provided with a hinged, weatherproof and lockable door. The external support legs can provide a Tee-Off bushing height of 1600mm, 1320mm and 1100mm.

Tee-Off Circuit Breaker

The tee-off circuit breaker comprises of three vacuum interrupters, which have a fault-make, fault-break rating. Opening of the circuit breaker is achieved by manually operating the handle as standard.

Earthing of the outgoing cable, from the Tee-off circuit breaker, is achieved by the use of the circuit breaker and in series with the off-load disconnect selector switch.

Ring Switches

The two ring switches are of the single break, fault-make / load-break 3 position types, 'ON', 'OFF' and 'EARTH'.

Operation

All operating positions and instructions are indicated on the main panel at the front of the unit. Operation is by means of manually independent mechanisms, which are mounted externally to the gas enclosure.

The Tee-off vacuum circuit breaker has two operating positions, 'ON' or 'OFF', with an off-load, interlocked selector allowing isolation & earthing of the Tee-off circuit.

A single, "Y"-bar type operating handle is stored at the front door. Symbols located on the end of the operating handle indicate direction of operation.

Test Facilities

Fully interlocked test facilities are provided in accordance with ENATS 41-36 requirements. Access to the test terminals is achieved by pulling a lever located on the front fascia inside the front door. This will allow the cover underneath the unit to drop down. Where cable test facilities are required on the Tee-off, an alternative interlocked system, using plug-in connectors, is available. The Sabre VRN2a has integral ring switch cable test facilities.

Interlocks

Positive safety interlocks are incorporated on all switch positions to prevent mal-operation.

Padlocks

All switch and selector positions can be padlocked.

Transformer Protection

The circuit breaker enables the VRN2a to protect transformers with ratings well in excess of those with a comparable HV fused unit. Protection is achieved by the use of ring core current transformers in combination with Time Lag Fuse links or a protection relay. The ring core current transformers are mounted around the rear tee-off bushings, external to the SF6 chamber, but within the cladding of the unit. The Time Lag Fuses, or the protection relay, are mounted behind a cover at the front of the unit.

SABRE VRN2a Dimensions

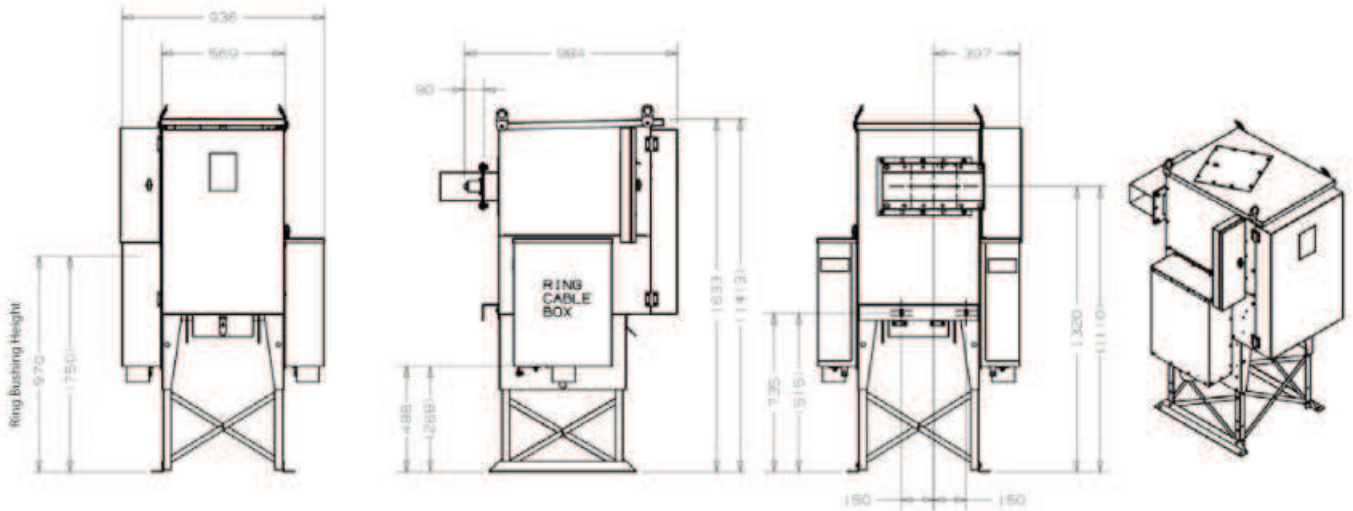

Bracketed dimensions are alternative lower height

Dimensions in millimetres

SABRE VRN2a Schematic line diagram

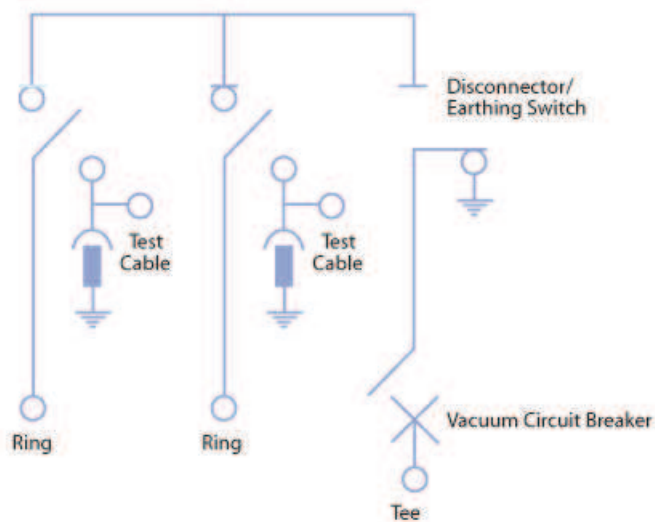

Technical data

(ratings in brackets are optional)

	Sabre VRN2a
Rated Voltage	12kV (15.5kV)
Impulse Withstand Voltage	75kV (95kV)
Normal Current	
Ring Switches	630A
Tee-Off Circuit Breaker	250A
Short Circuit Peak Making Current	
Ring Switches	50kA
Tee-Off Circuit Breaker	50kA
Short Circuit Breaking Current	
Tee-Off Circuit Breaker	20kA RMS
3 Second Short Time Current	
Ring Switches	20kA
Tee-Off Circuit Breaker	20kA
Earth Switch Peak Making Current	
Ring Switches	50kA
Tee-Off Circuit Breaker	7.9kA
Internal Arc Rating	
Freestanding	20kA 1 sec
Transformer Mounted	20kA 1 sec in ENA housing
Optional Cable Boxes Internal Arc Rating	
Standard	12.5kA 1 sec
Gas pressure	
Min Operating Pressure	0 Bar G
IP Rating	Up to IP54W
Weight	350kg
Testing standards	
BS EN 60265-1	*
BS EN 60129	*
BS EN 60694	*
BS EN 60298	*
IEC 60056	*
ENA TS 41-36	*
IEC 62271-102	*
IEC 62271-100	*
IEC 62271-103	*